

SERIE 41

KG 45 | 80.000 | 96

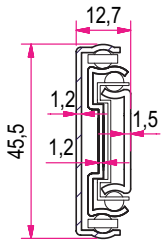

CARATTERISTICHE TECNICHE

ESTRAZIONE TOTALE

- Materiale: acc. lamin. a freddo
- Montaggio laterale
- Finitura: zincato brillante
- Sgancio frontale del cassetto
- Movimento silenzioso
- Cuscinetti a sfere in acciaio al carbonio
- Sistema "Sping&Apri"

TECHNICAL SPECIFICATIONS

FULL EXTENSION

- Material: cold rolled steel
- Side mounting
- Finishing: bright zinc-coated
- Drawer front disconnect
- Silent movement
- Carbon steel ball bearings
- Push&Rebound system

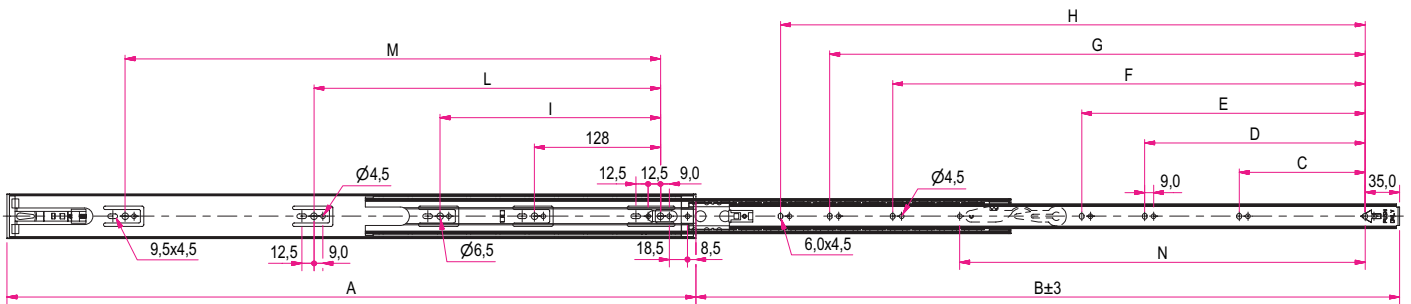

SISTEMA "SPINGI&APRI"
PUSH&REBOUND SYSTEM

CODE	A	B	C	D	E	F	G	H	I	L	M	N	CARTON Kg.	CARTON PAIR
41300	300	300	200	-	-	-	-	-	-	-	-	-	8.30	10
41350	350	350	96	-	-	-	-	256	192	-	-	236	10.30	10
41400	400	405	128	-	-	-	-	294	224	-	-	262	12.30	10
41450	450	460	96	160	-	-	-	344	288	-	-	288	13.90	10
41500	500	510	96	160	352	-	-	394	224	352	-	313	14.90	10
41550	550	585	128	192	384	-	-	444	224	352	-	338	16.10	10
41600	600	634	128	224	416	-	-	494	224	352	448	362	17.50	10
41650	650	665	128	224	416	480	-	544	224	352	480	387	19.20	10
41700	700	715	128	224	288	480	544	594	224	352	544	412	20.80	10